

# GSL1MH-E-R-47L

## SURFACE MOUNT GLASS PASSIVATED RECTIFIER

VOLTAGE: 1000V

CURRENT: 1.0A



### FEATURE

For surface mount pick and place application  
Low profile package  
Built-in strain relief  
High surge capability  
High temperature soldering guaranteed  
260°C/10sec at terminals  
Halogen Free

### MECHANICAL DATA

Terminal: Solderable per J-STD-002  
Case: Molded with UL-94 class V-0 recognized Halogen Free Epoxy  
Polarity: color band denotes cathode  
Marking: S1MH

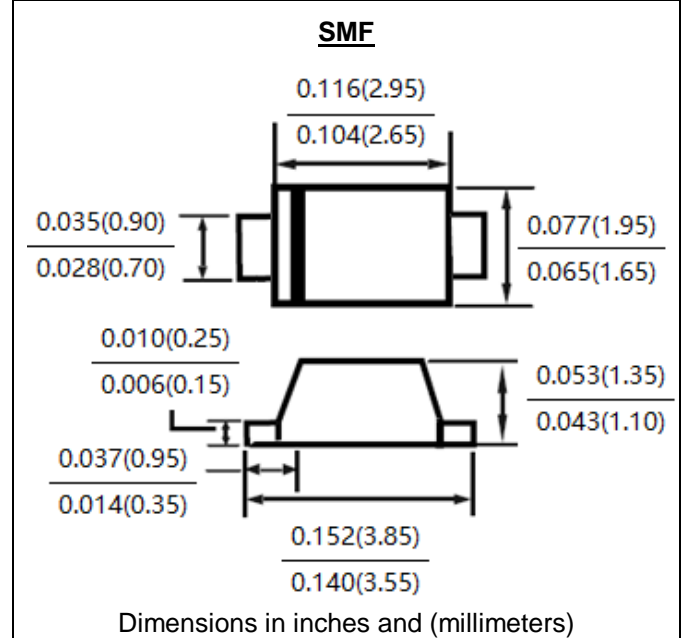

### MAXIMUM RATINGS AND ELECTRICAL CHARACTERISTICS

(single-phase, half-wave, 60Hz, resistive or inductive load rating at 25°C, unless otherwise stated)

	Symbol	GSL1MH-E-R-47L	units
Maximum Recurrent Peak Reverse Voltage	V <sub>rrm</sub>	1000	V
Maximum RMS Voltage	V <sub>rms</sub>	700	V
Maximum DC blocking Voltage	V <sub>dc</sub>	1000	V
Maximum Average Forward Rectified Current 3/8"lead length at T <sub>L</sub> =110°C	I <sub>f(av)</sub>	1.0	A
Peak Forward Surge Current 8.3ms single half sine-wave superimposed on rated load	I <sub>fsm</sub>	30	A
Maximum Instantaneous Forward Voltage at rated Forward current	V <sub>f</sub>	1.1	V
Maximum DC Reverse Current at rated DC blocking voltage	I <sub>r</sub>	5.0 300.0	μA
Reverse Recovery Time (Note1)	T <sub>rr</sub>	1000~2000	nS
Typical Junction Capacitance (Note 2)	C <sub>j</sub>	9.0	pF
Typical Thermal Resistance (Note 3)	R <sub>th(jl)</sub> R <sub>th(ja)</sub> R <sub>th(jc)</sub>	21 62 22	°C/W
Storage and Operating Junction Temperature	T <sub>j</sub> , T <sub>stg</sub>	-50 to +150	°C

- Note:
- Reverse Recovery Condition I<sub>f</sub> =0.5A, I<sub>r</sub> =1.0A, I<sub>rr</sub> =0.25A
  - Measured at 1.0 MHz and applied voltage of 4.0Vdc
  - Thermal Resistance from junction to ambient and from junction to lead mounted on P.C.B. with 3x3mm copper pad area

**Fig. 1 – Forward Current Derating Curve**

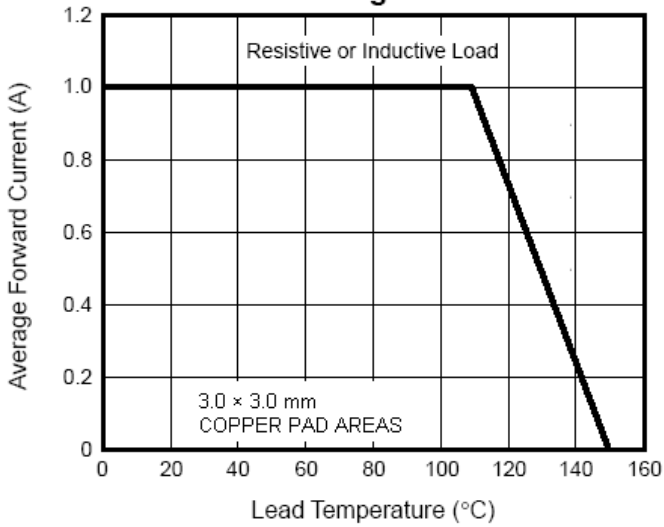

**Fig. 2 – Maximum Non-Repetitive Peak Forward Surge Current**

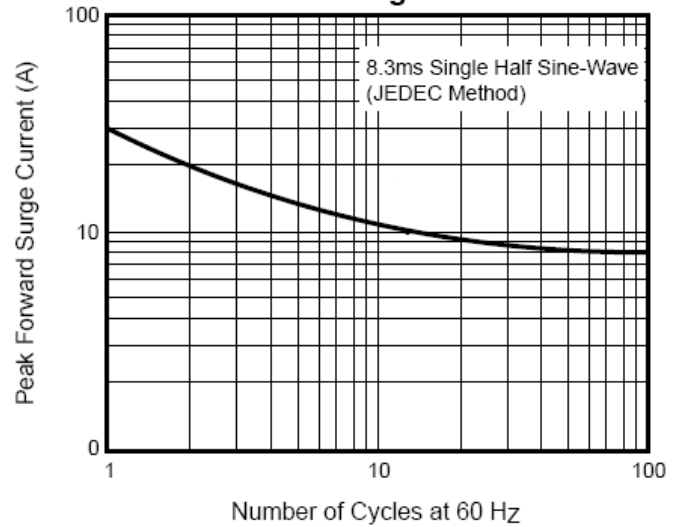

**Fig. 3 – Typical Instantaneous Forward Characteristics**

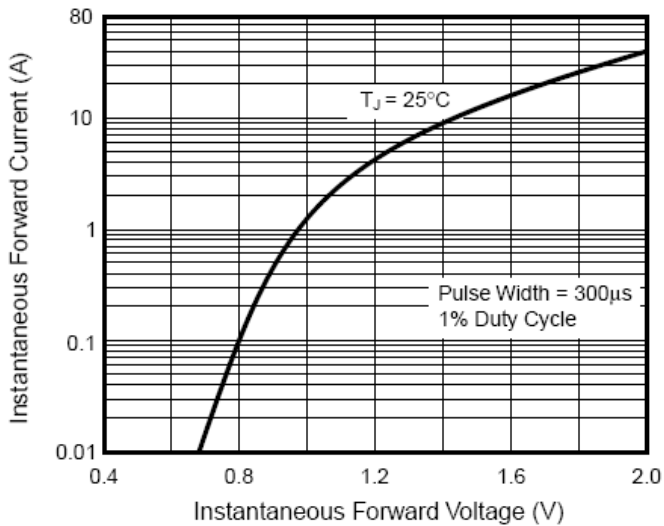

**Fig. 4 – Typical Reverse Leakage Characteristics**

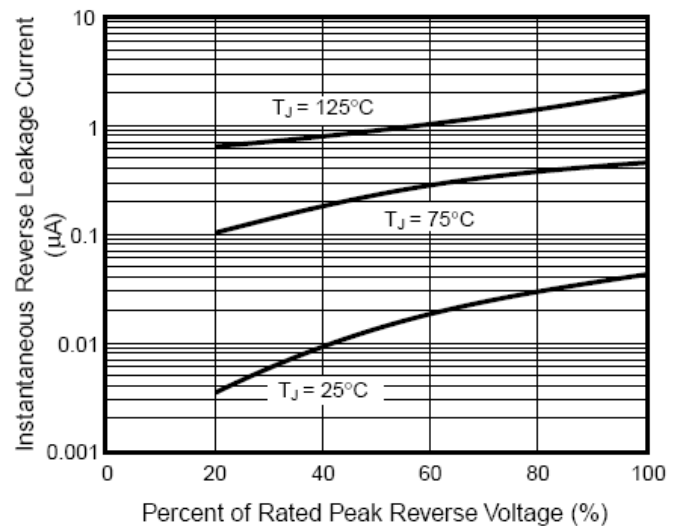

**Fig. 5 – Typical Junction Capacitance**

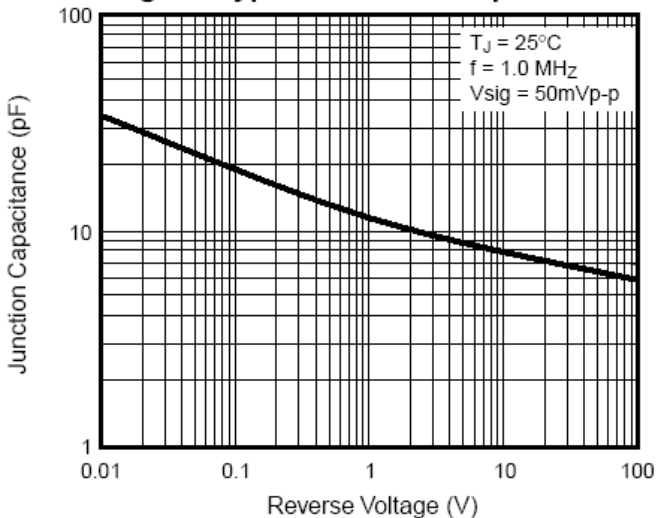

---

MOUNTING PAD GSL1MH-E-R-47L

---

SMF

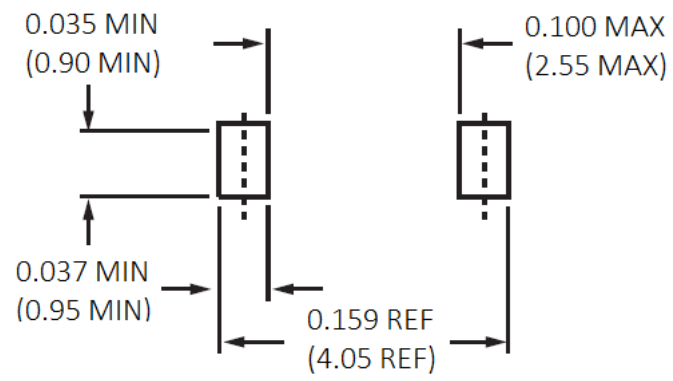

7 寸塑料盘

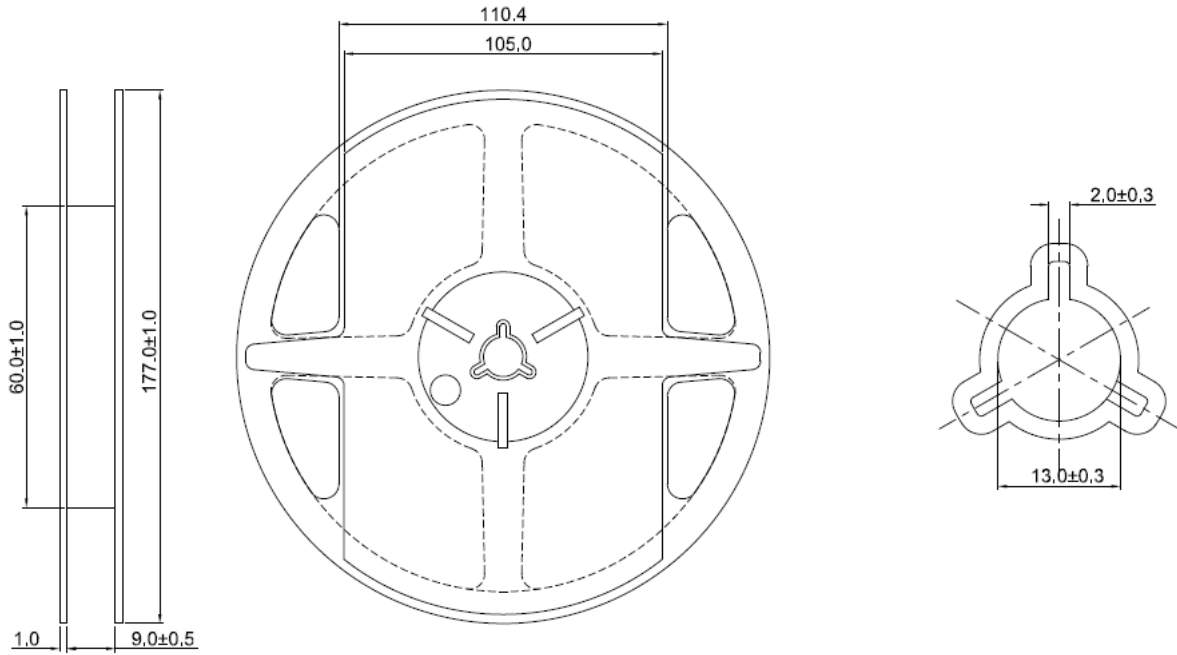

unit: mm

透明载带

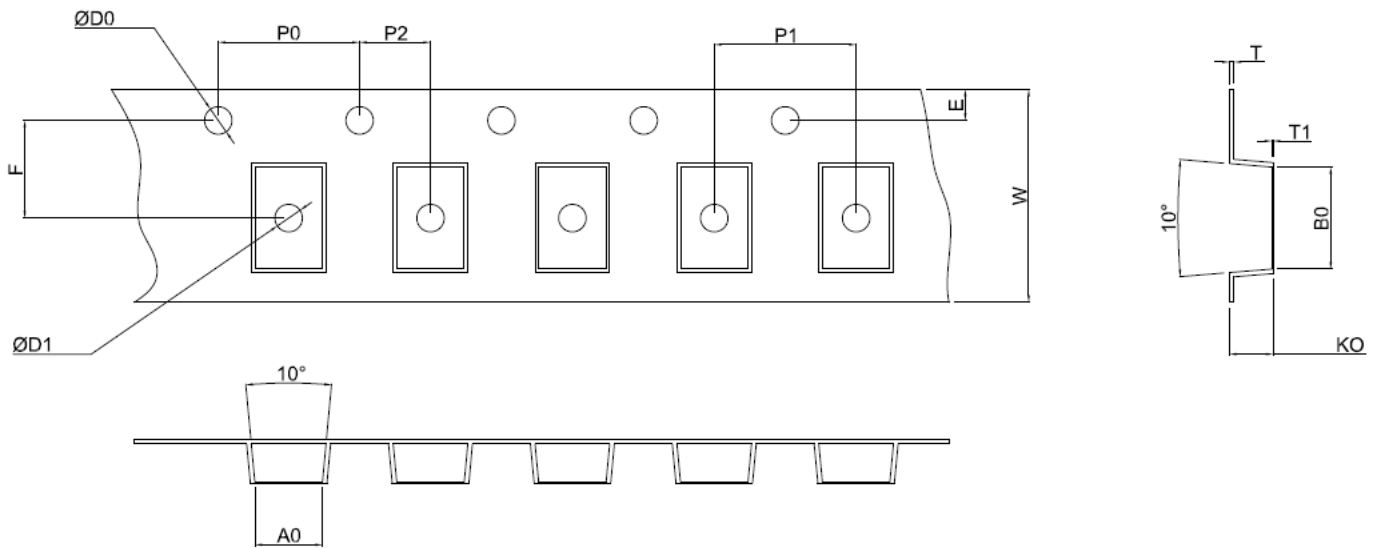

unit: mm

W	E	F	D0	D1	P0	P1	P2	A0	B0	KO	T	T1	10*P0
8,00±0,10	1,75±0,10	3,50±0,05	1,55±0,05	1,10±0,05	4,00±0,10	4,00±0,10	2,00±0,05	2,05±0,10	3,95±0,10	1,45±0,10	0,21±0,03	≥0,05	40,00±0,20

Units Per Reel (pcs)	Qty Per Inner Box (pcs)	Qty Per Carton (pcs)	Net Weight (kg)	Approx. Gross Weight (kg)
3500	17.5K	140K	6.16	6.50