

## G4J

### SINTERED GLASS JUNCTION AVALANCHE RECTIFIER

VOLTAGE: 600V

CURRENT: 3.0A



#### FEATURE

Glass passivated  
Hermetically sealed package  
Low reverse current

#### MECHANICAL DATA

Case: G-4 sintered glass case  
Terminal: Plated axial leads solderable per MIL-STD 202E, method 208C  
Polarity: color band denotes cathode end  
Mounting position: any

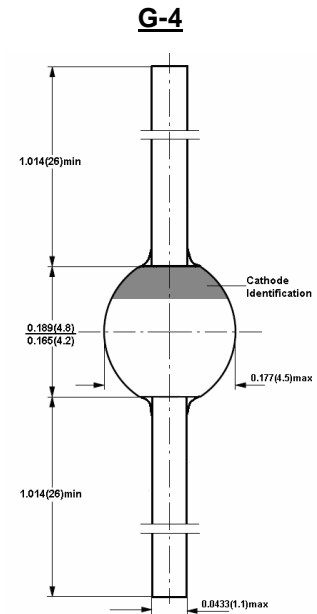

Dimensions in inches and (millimeters)

#### MAXIMUM RATINGS AND ELECTRICAL CHARACTERISTICS

(single-phase, half-wave, 60HZ, resistive or inductive load rating at 25°C, unless otherwise stated)

	SYMBOL	G4J	units
Maximum Recurrent Peak Reverse Voltage	$V_{RRM}$	600	V
Maximum RMS Voltage	$V_{RMS}$	420	V
Maximum DC blocking Voltage	$V_{DC}$	600	V
Maximum Average Forward Rectified Current 3/8"lead length at $T_a=70^\circ\text{C}$	$I_{FAV}$	3.0	A
Peak Forward Surge Current 8.3ms single half sine-wave superimposed on rated load	$I_{FSM}$	100	A
Maximum Forward Voltage at rated Forward Current and 25°C	$V_F$	1.1	V
Maximum DC Reverse Current at $V_{DC}=600\text{V}$ and 25°C	$I_R$	1.0	$\mu\text{A}$
Maximum DC Reverse Current at $V_{DC}=650\text{V}$ and 25°C	$I_R$	5.0	$\mu\text{A}$
Maximum DC Reverse Current at $V_{DC}=700\text{V}$ and 25°C	$I_R$	25.0	$\mu\text{A}$
Maximum DC Reverse Current at $V_{DC}=600\text{V}$ and 100°C	$I_R$	100	$\mu\text{A}$
Typical Reverse Recovery Time (Note 1)	$T_{rr}$	3.0	$\mu\text{S}$
Typical Junction Capacitance (Note 2)	$C_j$	40.0	pF
Typical Thermal Resistance (Note 3)	$R_{th}(ja)$	20.0	$^\circ\text{C}/\text{W}$
Storage and Operating Junction Temperature	$T_{stg}, T_j$	-65 to +175	$^\circ\text{C}$

Note:

1. Reverse Recovery Condition  $I_f=0.5\text{A}$ ,  $I_r=1.0\text{A}$ ,  $I_{rr}=0.25\text{A}$
2. Measured at 1.0 MHz and applied reverse voltage of 4.0Vdc
3. Thermal Resistance from Junction to Ambient at 3/8"lead length, P.C. Board Mounted

## RATINGS AND CHARACTERISTIC CURVES G4J

