

# FE1.5G

**SINTERED GLASS JUNCTION  
ULTRAFAST AVALANCHE RECTIFIER**  
VOLTAGE: 400V                      CURRENT: 1.5A



## FEATURE

Glass passivated  
Hermetically sealed package  
Low reverse current  
Soft recovery characteristics

## MECHANICAL DATA

Case: SOD-57 sintered glass case  
Terminal: Plated axial leads solderable per MIL-STD 202E, method 208C  
Polarity: color band denotes cathode end  
Mounting position: any

## SOD-57

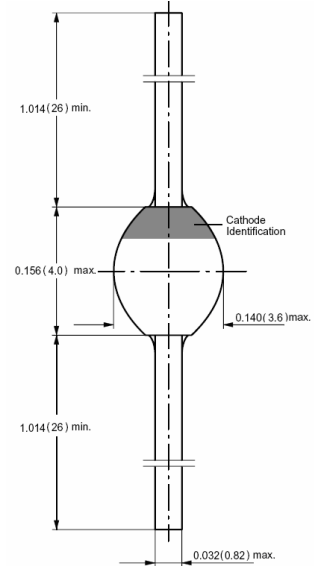

Dimensions in inches and (millimeters)

## MAXIMUM RATINGS AND ELECTRICAL CHARACTERISTICS

(single-phase, half-wave, 60HZ, resistive or inductive load rating at 25°C, unless otherwise stated)

	SYMBOL	FE1.5G	units
Maximum Recurrent Peak Reverse Voltage	$V_{RRM}$	400	V
Maximum RMS Voltage	$V_{RMS}$	280	V
Maximum DC blocking Voltage	$V_{DC}$	400	V
Maximum Average Forward Rectified Current 3/8"lead length at TL=55°C	$I_{FAV}$	1.5	A
Peak Forward Surge Current 8.3ms single half sine-wave superimposed on rated load	$I_{FSM}$	50	A
Maximum Forward Voltage at rated Forward Current and 25°C	$V_F$	1.6	V
Maximum DC Reverse Current at $V_{DC} = 400V$ and 25°C	$I_R$	5.0	$\mu A$
Maximum DC Reverse Current at $V_{DC} = 450V$ and 25°C	$I_R$	5.0	$\mu A$
Maximum DC Reverse Current at $V_{DC} = 500V$ and 25°C	$I_R$	25.0	$\mu A$
Maximum DC Reverse Current at $V_{DC} = 400V$ and 100°C	$I_R$	100	$\mu A$
Maximum Reverse Recovery Time (Note 1)	$T_{rr}$	35	nS
Typical Junction Capacitance (Note 2)	$C_j$	35.0	pF
Typical Thermal Resistance (Note 3)	$R_{th}(ja)$	45.0	°C/W
Storage and Operating Junction Temperature	$T_{stg}, T_j$	-65 to +175	°C

### Note:

1. Reverse Recovery Condition  $I_f = 0.5A, I_r = 1.0A, I_{rr} = 0.25A$
2. Measured at 1.0 MHz and applied reverse voltage of 4.0Vdc
3. Thermal Resistance from Junction to Ambient at 3/8"lead length, P.C. Board Mounted

## RATINGS AND CHARACTERISTIC CURVES FE1.5G

**FIG. 1 - FORWARD CURRENT DERATING CURVE**

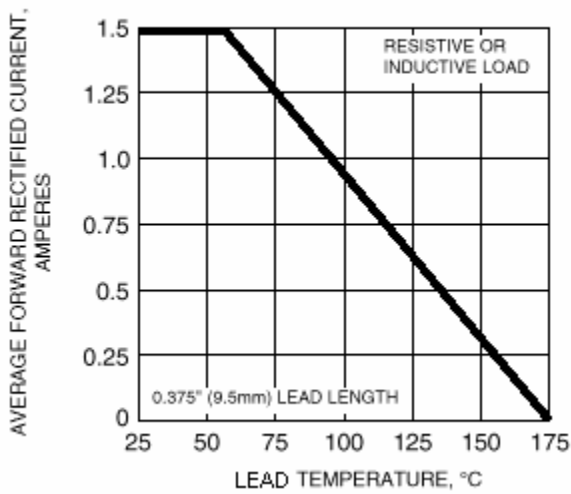

**FIG. 2 - MAXIMUM NON-REPETITIVE PEAK FORWARD SURGE CURRENT**

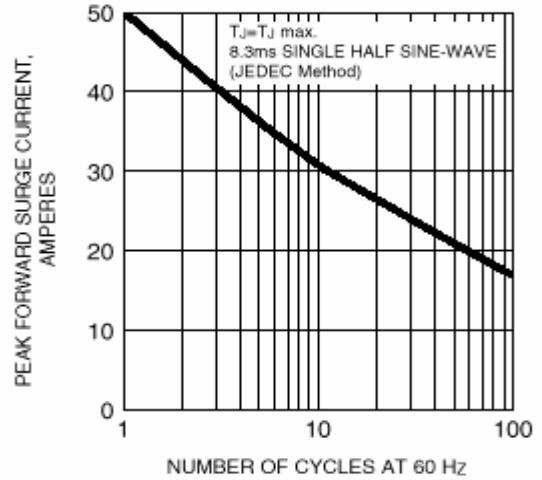

**FIG. 3 - TYPICAL INSTANTANEOUS FORWARD CHARACTERISTICS**

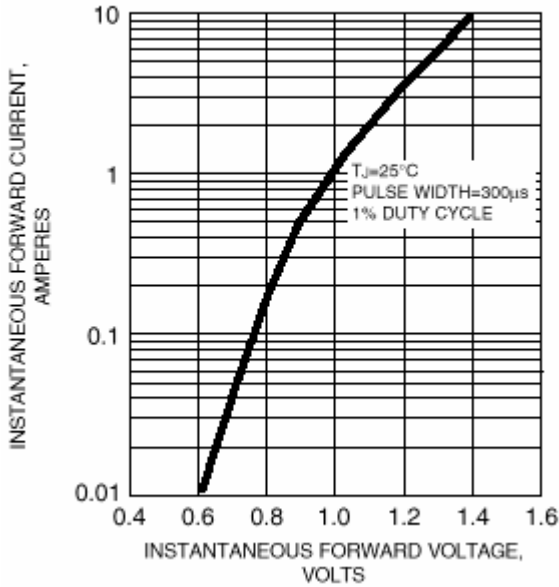

**FIG. 4 - TYPICAL REVERSE CHARACTERISTICS**

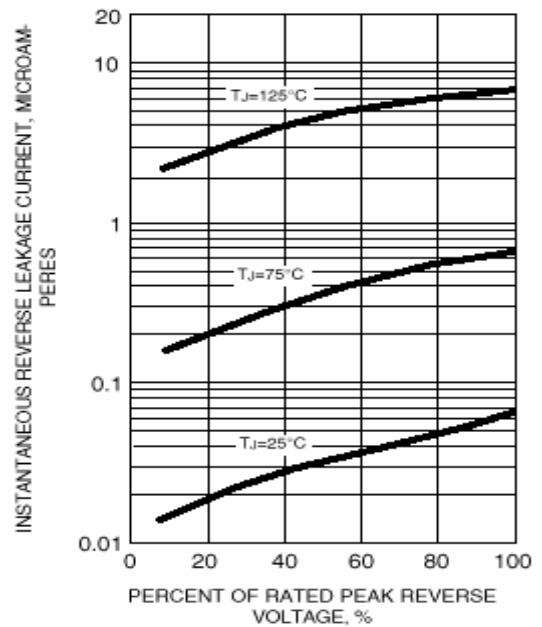

**FIG. 5 - TYPICAL JUNCTION CAPACITANCE**

